



RILEY CENTER
MISSISSIPPI STATE
UNIVERSITY™



Table of Contents.

Section 1: Venue overview

Section 2: Parking and load-in information

Section 3: Venue contacts

Section 4: Stage Specifications

Section 5: Power distribution information

Section 6: Lighting information

Section 7: Audio information

Section 8: In-house backline information

Section 9: Line set schedule

Venue Overview

The MSU Riley Center is a historic performance space located in downtown Meridian, Mississippi. Originally built as a Grand Opera House in 1889 the space was in operation until 1927 when it closed its doors. The building remained closed to the public for many decades only being used as storage space. In the 1990's a group formed with the idea of restoring the theater to its former glory. Eventually Mississippi State University became interested in the efforts to restore the venue and with the help of the Riley Foundation raised funds to begin the project in 2003. Finally in 2006 the Theater once again opened its doors to the public for the first time in 79 years. The theater is now a 935 seat concert space hosting a wide range of concerts and events.

During the revitalization process efforts were made to ensure that the historic theater would be capable of hosting concerts and all the basic needs of touring artist. However due to the historic nature of the facility, certain adjustments for most touring show are required. The first most obvious adjustment is the size of the stage. The proscenium opening is only 30 feet wide, so most show will need to adjust their spacing on stage. The next adjustment is the front of house audio position. The space allotted for the audio position is located house right with partial balcony cover. Seat kills are not possible due to sight lines for patrons and the limited number of seats. Another adjustment that must be made is the location of the lighting control. Lighting consoles must be placed in the lighting booth as seats kills are not possible. The lighting desk may be placed in the house during programming but must be moved for the show. Lastly, the historic theater is located on the second floor therefore load-in is through a freight elevator and depending on the size of the show may require multiple trips.

I hope this gives you some insight into the space that your show will be presented in. The MSU Riley Center is an amazing performance space with a rich history. We hope you will enjoy your time in our facility.

Andy Rainey

Technical Director

MSU Riley Center

arainey@riley.msstate.edu

Parking and load-in information.

Directions from I-20: Take exit 153 and go north on 22Ave. about 1 mile. Turn left onto 6th street. Look for the Loading Zone which will be to the left between Mississippi State University's building and a WWI Memorial. First Bus or Truck should be parked closest to the left-hand curb with the back of the trailer facing the loading doors. (Large green framed class doors.) Additional Vehicles should park the same direction side by side. Shore power is live and marked. Contact the Technical Director, Andy Rainey, if you need more information. Cell: (601) 934-2065.

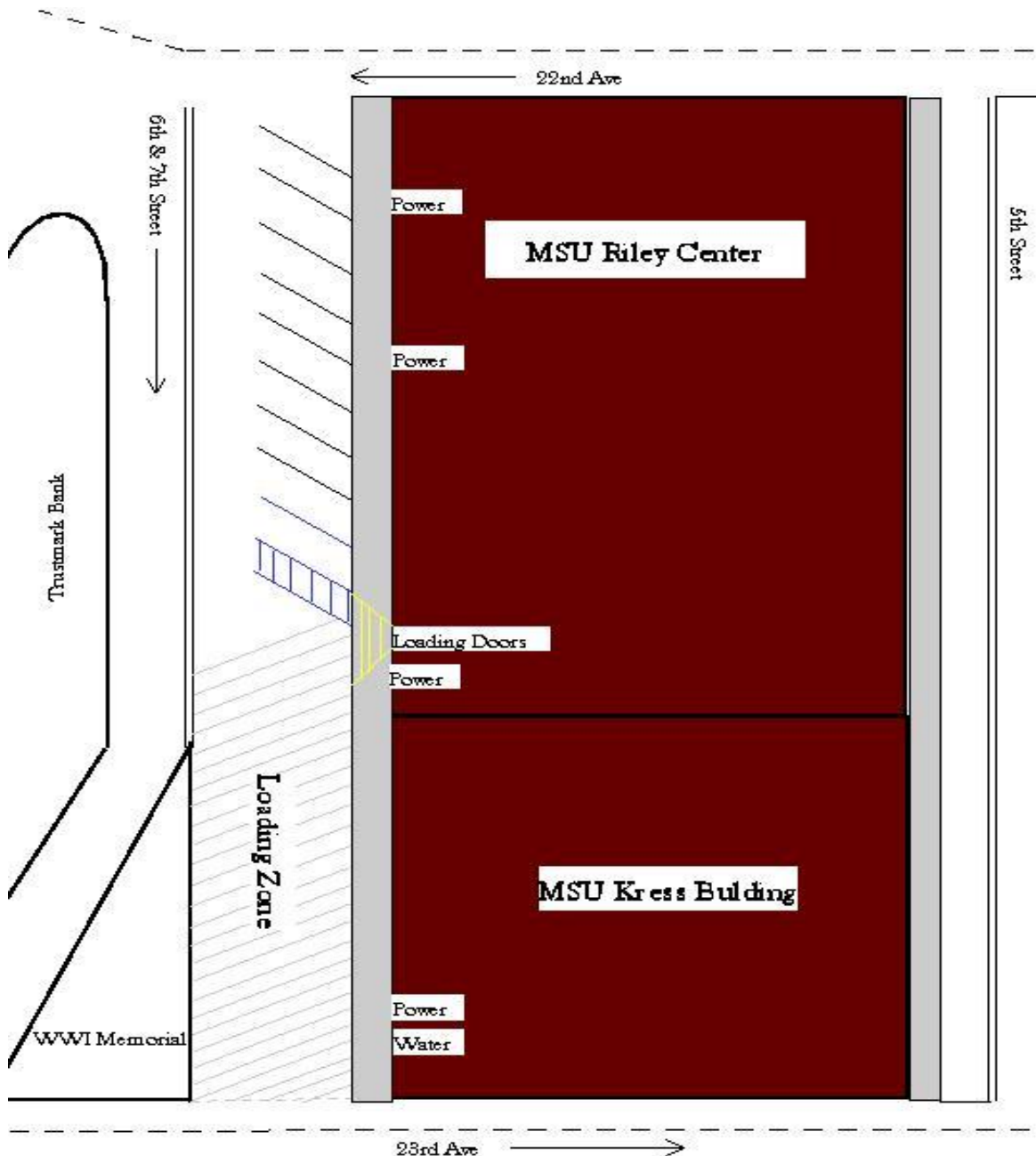

Section 2 continued

Load-in: Load-in is street level with a push to our freight elevator. The freight elevator is 14'x10'x9'h and has a 6000lb capacity. If your load-in requires a forklift, please notify us during the production advance.

Section 3

Venue Contacts.

Technical Director: Andy Rainey

Office: 601-696-2211

Cell: 601-934-2065

Email: arainey@riley.msstate.edu

Box Office Manager: Jennifer Haught

Office: 601-696-2206

Email: jhaught@riley.msstate.edu

Contracts/Merch: Morgan Dudley

Office: 601-696-2203

Email: mdudley@riley.msstate.edu

Hospitality/Catering: Gwen Blakely

Office: 601-696-2213

Email: gblakely@riley.msstate.edu

Business Coordinator: Mindy Huebner (Hotel info, Settlement)

Office: 601-696-2204

Email: mhuebner@riley.msstate.edu

Campus Police: Lt. Breonne Spikes

Cell: 601-934-0863

Email: bspikes@meridian.msstate.edu

Stage Specifications.

Stage Dimensions:

Proscenium: 29' 4" w 19' 4" h

Depth 32' 6"

Apron 7' 2" at center

Wing left - 8' 4"

Wing right - 12' 6"

Stage is 41" above audience floor

Floor is maple with dark brown stain. Sprung for dance. No screw or lags.

Orchestra Pit Dimensions:

Width upstage: 22'6"

Width downstage: 26'5"

Depth: At Center 18', On Sides 15'

Manual pit fill with heights set to stage, audience, or pit level.

Line set data:

Grid height 50' 7"

Batten high trim 48' 8"

Batten low trim 4'

Battens 1½" Schedule 40, 38' long, 4 lift lines on 11'4" centers

36 single purchase, 9 double purchase (see line set schedule)

Arbor capacity - see line set schedule

Loading - high gallery

Operating - 2-36 SL floor, 1 and 37-45 SL mid gallery

Available weight - 5 ton (estimated)

Section 4 continued

Drapery:

See line set schedule for locations

Main Act – Brick red with gold trim, will fly or travel, manual operation

Legs – 2 sets black velour 24' x 12'

Teasers – 1 brick red with gold trim 34' x 9' with fullness

3 black velour 40' x 6' with fullness

Travelers – 2 black velour 24'x 40', operate SL

Blackout – 24'x40' no fullness

Scrim – 24'x40' black

Bounce – 24'x40' white

Crossover:

Hallway behind the stage.

FOH access:

Stage left through a storage room hallway and removable stairs at center.

Dressing Rooms:

Six total, 5 with showers. All have lavatories. Three star dressing rooms are located at stage level, and three chorus dressing rooms are on other floors.

Production office with internet and phone.

Keys are available upon request.

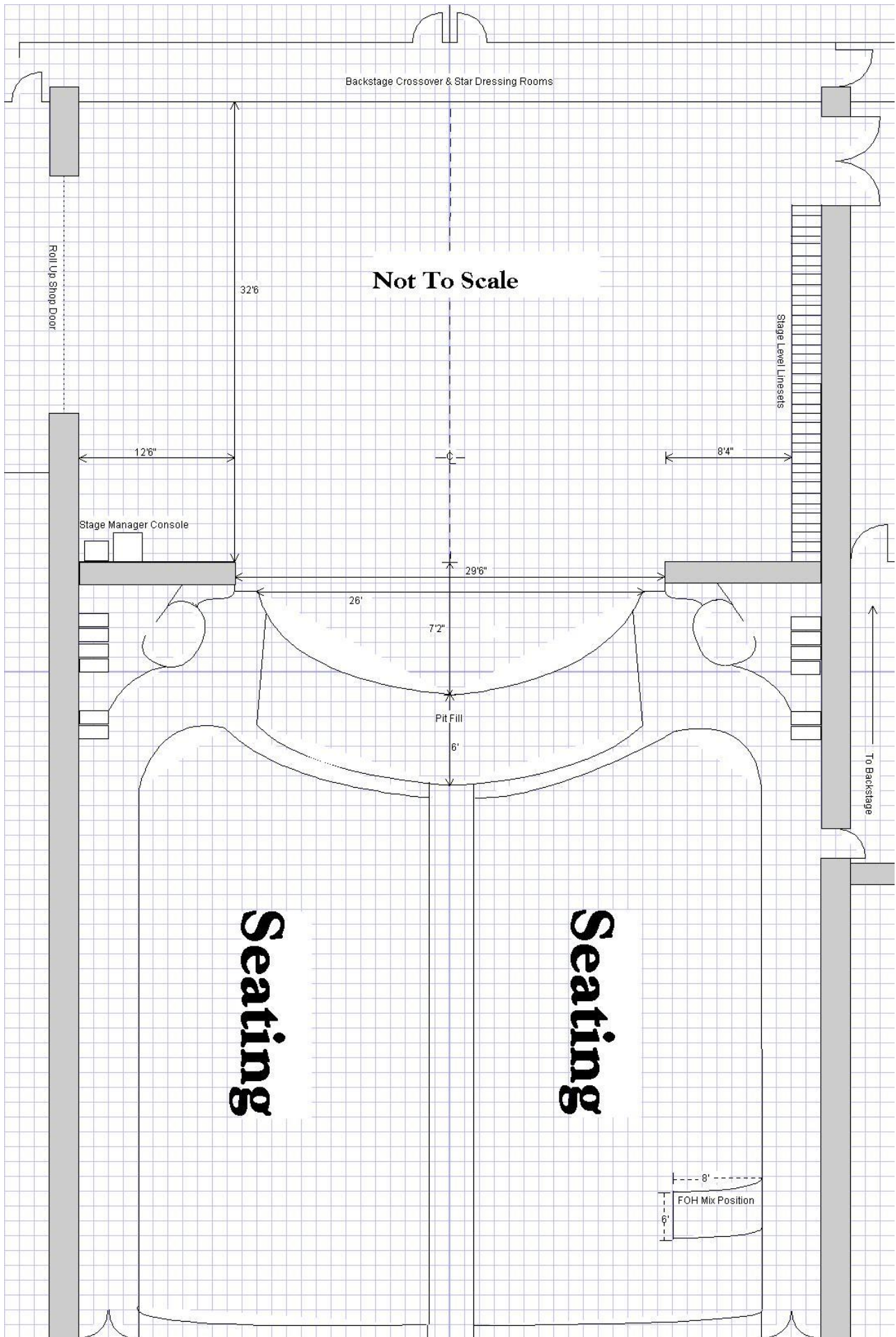

Power distribution information.

Lighting:

250 amp, 3 phase located stage right in the stage workshop 20 feet from the stage right wing. Four 20-amp Stage Pin, four 20 amp Edison, and one 50 amp single phase Range Plug on stage right and stage left.

Audio:

200 amp, 3 phase isolated located stage right in the stage workshop 25 feet from the stage right wing. Orange colored quad 20-amp Edison located in each corner of the stage and at front of house.

Shore Power:

Five 50-amp, single phase bus shore power locations on sidewalk. (locations are shown on the parking map.

Lighting information.

Control:

High End Systems Hedge Hog 4X with 6 universes over SACN.

ETC Expression 3 with 4 universes over EDMX.

House and Lobbies control via ETC Unison Architectural control.

Dimmers:

204 2.4kW ETC Dimmers

Section 5 continued

Fixtures:

25 Blizzard Flurry Z moving led wash
20 ADJ Focus Spot 5Z moving led spot
8 Blizzard Hotstik 5 COBII led batten wash
130 S-4 575w (6 – 10deg, 20 – 14deg, 27 – 19deg, 34 – 26deg,
40 – 36deg, 20 – 50deg)
48 S-4 PAR 575w
12 S-4 Parnel 575w
12 Altman Fresnel 750w
8Altman 3cell far-cyc
Cable and accessories
2 Lycian 1209 575w follow spots

Lighting Positions:

2 FOH slots with 22 circuits each, 2 box booms 6 circuits' ea.
Six circuits on balcony rail
4 OS electrics
Cyc electric upon request.
Follow spots are far left and right in the top balcony.

Video

Panasonic PT-MK20 20,000 Lumen Projector (Mounted on Balcony)
16' x 9' Projection Screen

Current as of April 2026

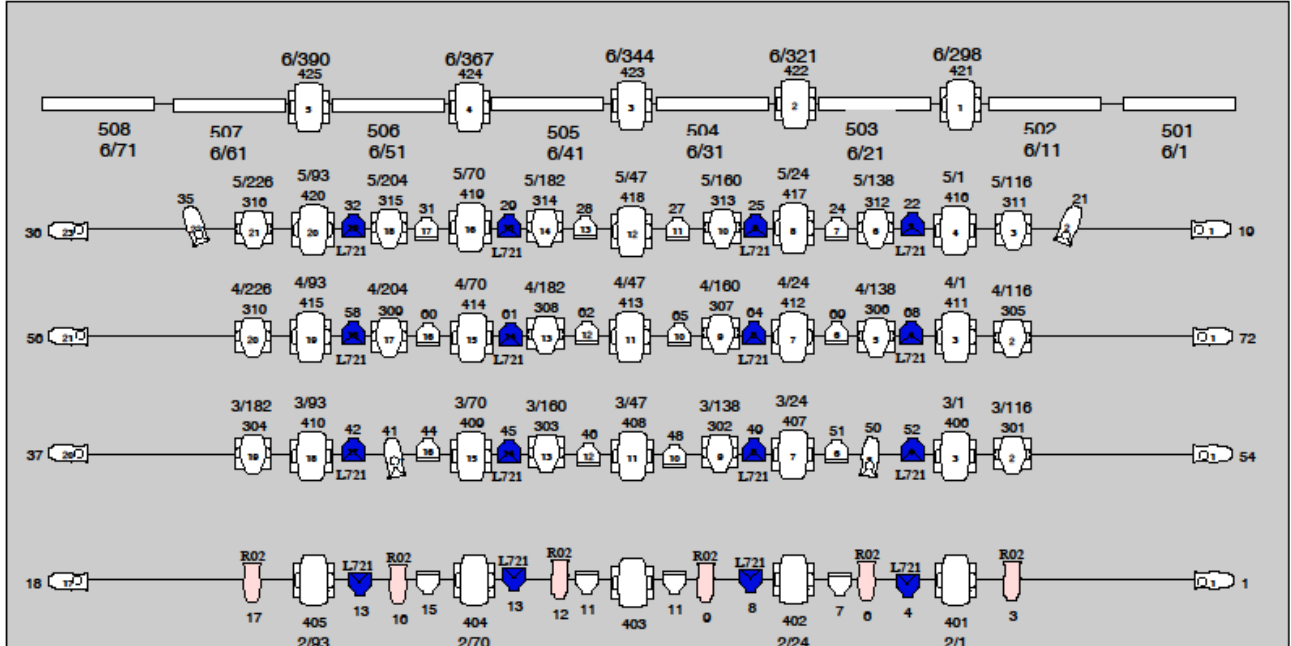

Parked: 5, 10, 14, 23, 26, 30, 34, 39, 43, 47, 55, 59, 63, 67, 73, 74, 75, 79, 239, 240

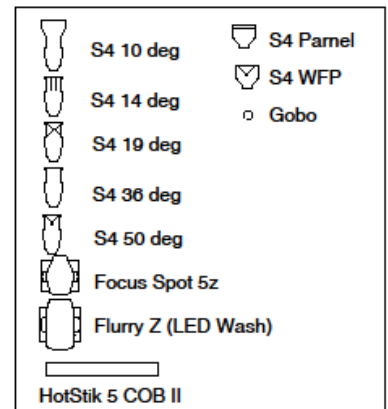
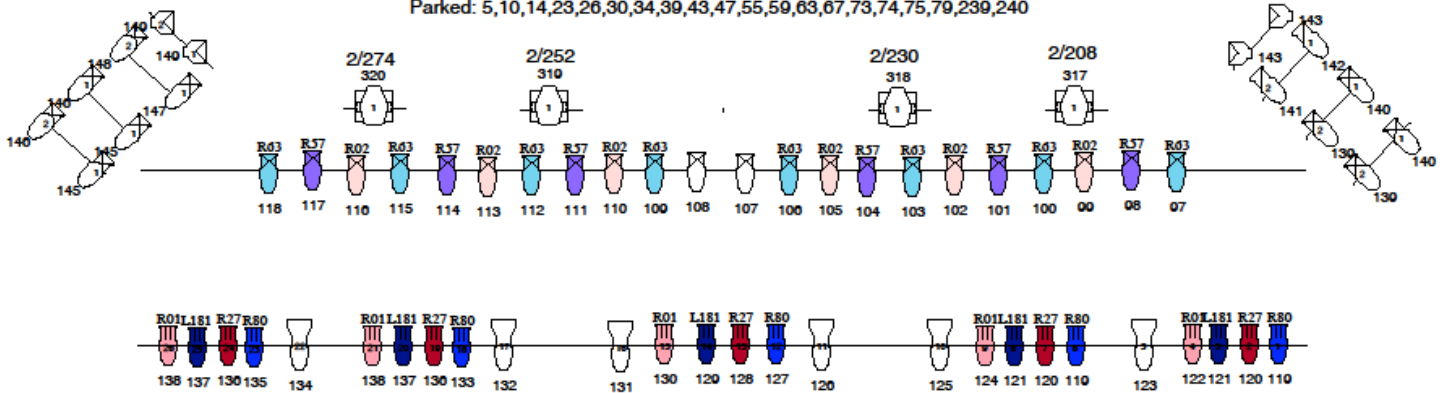

Audio information.

Front of house:

FOH - Fully tuned and ready to use Meyer PA, with JM1-P main arrays. 1100 LFC low frequency speakers. Out-fills, down-fills, balcony fills, and front fills. Processing for speakers is Meyer Galileo Galaxy controllers. Installed 2019.

Consoles:

Yamaha CL5

Yamaha DM7EX

(2) Peavey PV6 personal mixers

Crest x18 rackmount analog mixer

Stage racks:

2 Yamaha Rio 3224-D2 set up for gain sharing between consoles.

Monitors:

8 Sennheiser EW IEM G4 Transmitters with 10 belt pack receivers.

14 Peavey QW series wedges (15"LF, 4"HF)

12 Crest Pro 9200

Monitor processing via Peavey Media Matrix Nions

Side fills-2 Peavey ILS 1294V tops with 2 Peavey 118 subs

Dressing room monitors with paging

Clearcom production intercom

Microphones:

4 - AKG C414

4 - Sennheiser MD421

2 - EV RE20

4 - Shure SM81

1 - Shure B52

Section 7 continued

- 1 – Shure B91**
- 1 – AKG D112**
- 2 – Crown PCC160**
- 5 – Sennheiser E604**
- 2 – Shure MX202 with 184 capsules**
- 2 – Shure MX202 with 185 capsules**
- 6 – Shure SM57**
- 5 – Shure B57**
- 14 – Shure SM58**
- 2 – Shure B58**
- 2 – Shure B98 H/C**
- 2 – DPA 4099 with piano, guitar, double bass and cello clips.**
- 2 – Point Source Audio CO-6 head worn mics for Shure belt packs.**
- 2 – AKG CK31**
- 4 – Shure Countryman black B3 lavalier**

Wireless:

- 3 – Shure ULXD dual channel receivers with Dante**
- 6 – Shure ULXD handheld w/Beta 87A capsules**
- 4 – Shure ULXD bodypacks**
- 1 – Sennheiser E300 receiver**
- 1 – Sennheiser SKM300/865 G3 handheld**
- 1 – Sennheiser E300 bodypack w/lavalier**

Section 7 continued

Direct Boxes:

- 6 – Countryman Active
- 5 – Proformance passive
- 2 – Whirlwind Director
- 1 – Peavey Stereo USB DI
- 2 – Radial JDI
- 2 – Radial ProD2 passive stereo

Section 8

Backline information.

The following backline equipment is available in house at the MSU Riley Center.

Instruments:

Yamaha C-7 Piano (new 2008) with adjustable bench.

Yamaha Montage 8

Celesta 5 1/2a

Yamaha Maple Tour Custom Drum-set includes:

22" Bass drum, 10" tom, 12" tom, 14" tom, 16" tom

14"x6.5" brass snare, 14"x6.5" wood snare (both Yamaha)

14"X6.5" Pearl Philharmonic Concert snare

Zildjian A Custom cymbals- 20" med ride thin, 18" crash thin, 17" crash thin, 16" crash thin, 10" splash paper thin, 14" hi-hat pair

Zildjian Constantinople (2) 16" vintage orchestra med. light, (2) 18" vintage orchestra med. heavy, (2) 20" vintage orchestra med. light, (1) 18" suspended.

Single Bass pedal, double bass pedal – Yamaha 800 series

Snare stands, High-hat, 6 cymbal stands – Yamaha 800 series

Section 8 continued

Round throne, Roc-n-N-Soc Nitro with back

Drum shield

Several different drumheads available.

Cowbells, shakers, tambourines.

Adams Timpani Set (23",26",29", 32")

Pearl Concert Bass Drum

Sabian 30" and 40" gong

Yamaha Glockenspiel

Deagan Concert Chimes

Adams Xylophone 4 octave

Adams Vibraphone 3 octave

Guitar Amps:

Peavey Classic 50 212

Peavey Classic 50 410

Trace Elliot TA-300 Acoustic Amp

Peavey Pro 500 Bass Head

Pro 810 Cabinet

Tour 210 Cabinet

Trace Elliott 1215 with -1x15 bass cabinet and

4x10 bass cabinet

Peavey KB5 keyboard amp

Check with your musicians and see what is acceptable. As soon as I hear from you on this I can get on the rest of the backline.

Section 9

Line set schedule.

Line Number	Distance US	Line Capacity	Current Use	Notes
1	1'2"	1200sp	Main Teaser	May not be moved
2	1'10"	1200sp	Main Act	May not be moved
3	2'6"	1200sp		
4	3'2"	1800sp	1 st Electric	Permanent strip
5	3'10"	1200sp		
6	4'6 1/2"	1200sp		
7	5'2"	1200sp		
8	5'10"	1200sp	Legs	
9	6'6"	1200sp		
10	7'2 1/2"	1800sp	Shell	May not be moved
11	7'10"	1200sp		Obstructed
12	8'6"	1200sp		
13	9'2"	1200sp		
14	9'10"	1200sp	Teaser	
15	10'6"	1200sp	Traveller	May not be moved
16	11'2"	1200sp		
17	11'10"	1200sp	Electric	Cable drop
18	12'6"	1200sp		
19	13'4"	1200sp		
20	14'1"	1200sp		
21	14'8"	1200sp		
22	15'4"	1200sp		
23	16'0"	1200sp	Teaser	
24	16'8"	1200sp	Legs	
25	17'4"	1800sp	Shell	May not be move
26	18'0"	1200sp		Obstructed
27	18'8"	1200sp	Electric	Cable drop
28	19'4"	1200sp		
29	19'11"	1200sp		
30	21'0"	1200sp		
31	21'8"	1200sp		
32	22'5"	1200sp		
33	23'0"	1200sp	Teaser	
34	23'7"	1200sp	Traveller	May not be moved
35	24'3"	1800sp		
36	24'11"	1200sp	Electric	Permanent strip
37	26'8"	1200sp		
38	27'2"	1800dp	Shell	May not be moved
39	27'10"	1200dp		Obstructed
40	28'6"	1200pd		
41	29'2"	1200dp	Cyc lights	Cable drop
42	29'10"	1200dp		
43	30'6"	1200dp	Blackout	
44	31'2"	1200dp		
45	31'10"	1200dp	Cyclorama	
Back Wall	33'5"			Updated 10/12/20